

5.6 kVA

PowerPact™ Residential Standby Generator Air-Cooled Gas Engine

INCLUDES:

- True Power™ Electrical Technology
- Digital LED Controller
- Rugged Galvaneal Steel Rust Resistant Sound Attenuated Enclosure
- External Main Circuit Breaker and Control Panel Access
- UL 2200 Listed
- Rated for winds up to 180 MPH
- Flexible Fuel Line Connector
- Direct-To-Dirt Composite Mounting Pad
- Natural Gas or LP Gas Operation
- 3 Year Limited Warranty
- Capability to be installed within 18" (457 mm) of a building*

Standby Power Rating
Model G006520-1 (Steel - Bisque) - 5.6 kVA 50 Hz



*Built in the USA using domestic and foreign parts

*Only if located away from doors, windows and fresh air intakes, and unless otherwise directed by local codes.

FEATURES

- **INNOVATIVE DESIGN & PROTOTYPE TESTING** are key components of GENERAC'S success in "IMPROVING POWER BY DESIGN." But it doesn't stop there. Total commitment to component testing, reliability testing, environmental testing, destruction and life testing, plus testing to applicable CSA, NEMA, EGSA, and other standards, allows you to choose GENERAC POWER SYSTEMS with the confidence that these systems will provide superior performance.
- **TEST CRITERIA:**
 - ✓ **PROTOTYPE TESTED**
 - ✓ **SYSTEM TORSIONAL TESTED**
 - ✓ **NEMA MG1-22 EVALUATION**
 - ✓ **MOTOR STARTING ABILITY**
- **POWERPACT™:** Offers an extreme value for those who desire automatic backup power at the most affordable price.
- **SINGLE SOURCE SERVICE RESPONSE** from Generac's extensive dealer network provides parts and service know-how for the entire unit, from the engine to the smallest electronic component.

PowerPact™ System - 5.6**Engine**

- Generac (OHV) design Maximizes engine “breathing” for increased fuel efficiency. Plateau honed cylinder walls and plasma moly rings helps the engine run cooler, reducing oil consumption resulting in longer engine life.
- Cast iron cylinder walls Rigid construction and added durability provide long engine life.
- Low oil pressure shutdown system Shutdown protection prevents catastrophic engine damage due to low oil.
- High temperature shutdown Prevents damage due to overheating.

Generator

- Revolving field Allows for a smaller, light weight unit that operates 25% more efficiently than a revolving armature generator.
- Skewed stator Produces a smooth output waveform for compatibility with electronic equipment.
- Displaced phase excitation Maximizes motor starting capability.
- Automatic voltage regulation Regulates the output voltage to $\pm 5\%$ prevents damaging voltage spikes.
- UL 2200 listed For your safety.

Digital Controls

- Multiple LED annunciation Provides specific system information without having to open the generator enclosure.
- Auto/Off/Manual buttons Select the operating mode.
- Utility voltage sensing Constantly monitors utility voltage, setpoints 65% dropout, 80% pick-up, of standard voltage.
- Utility interrupt delay Prevents nuisance start-ups of the engine, setpoint approximately 5 seconds.
- Engine warm-up Ensures engine is ready to assume the load, setpoint approximately 30 seconds.
- Engine cool-down Allows engine to cool prior to shutdown, setpoint approximately 1 minute.
- Seven day exerciser Operates engine to prevent oil seal drying and damage between power outages.
- Smart battery charger Maintains battery charge level to ensure starting.
- Main line circuit breaker Protects generator from overload.
- Multiple protection features Prevents additional damage from occurring within the generator if a fault condition arises.

Unit

- UL weather protective enclosure Sound attenuated enclosure ensures quiet operation and protection against mother nature. Three panels are removable for easy service and maintenance access.
- Enclosed critical grade muffler Quiet, critical grade muffler is mounted inside the unit to prevent injuries.
- Small, compact, attractive Makes for an easy, eye appealing installation, as close as 18" away from a building.

Installation System

- 1 ft (305 mm) flexible fuel line connector Absorbs any generator vibration when connected to rigid pipe.
- Direct-to-dirt composite mounting pad Complex lattice design prevents settling or sinking of the generator system.

PowerPact™ System - 5.6

Generator

Model	G006520-1
Rated Maximum Continuous Power Capacity (LP)	5600 VA
Rated Maximum Continuous Power Capacity (NG)	5000 VA
Rated Voltage	220
Rated Maximum Continuous Load Current – 240 Volts (LP/NG)	25.5 / 22.7
Main Line Circuit Breaker	32 Amp
Phase	1
Number of Rotor Poles	2
Rated AC Frequency	50 Hz
Power Factor	1.0
Battery Requirement (not included)	Group U1, 12 Volts and 300 CCA Minimum
Unit Weight (lb/kg)	330/150
Dimensions (L x W x H) in/mm	36 x 27 x 25/915 x 676 x 640
Sound output in dB(A) at 23 ft (7 m) with generator operating at normal load**	67

Engine

Type of Engine	GENERAC OHV	
Number of Cylinders	1	
Displacement	420 cc	
Cylinder Block	Aluminum w/ Cast Iron Sleeve	
Valve Arrangement	Overhead Valve	
Ignition System	Solid-state w/ Magneto	
Governor System	Mechanical	
Starter	12 VDC	
Oil Capacity Including Filter	Approx. 1.2 qt/1.1 L	
Operating rpm	3000	
Fuel Consumption		
Natural Gas	ft ³ /hr (m ³ /hr)	
	1/2 Load	81 (2.29)
	Full Load	120 (3.42)
Liquid Propane	ft ³ /hr (gal/hr) [l/hr]	
	1/2 Load	24.4 (0.67) [2.54]
	Full Load	41.5 (1.14) [4.32]

Note: **Fuel pipe must be sized for full load.** Required fuel pressure to generator fuel inlet at all load ranges - 3.5-7" water column (7-13 mm mercury) for natural gas, 10-12" water column (19-22 mm mercury) for LP gas. For Btu content, multiply ft³/hr x 2500 (LP) or ft³/hr x 1000 (NG). For Megajoule content, multiply m³/hr x 93.15 (LP) or m³/hr x 37.26 (NG)

Controls

LED Indicators	Simple user interface for ease of operation.
Mode Switch: Auto	Automatic Start on Utility failure. 7 day exerciser.
Off	Stops unit. Power is removed. Control and charger still operate.
Manual/Test (start)	Start with starter control, unit stays on. If utility fails, transfer to load takes place.
Engine Start Sequence	Cyclic cranking: Engine cranks a maximum of five times at factory set intervals and durations
Engine Warm-up	30 sec
Engine Cool-Down	1 min
Starter Lock-out	Starter cannot re-engage until 5 sec after engine has stopped.
2.5 Amp Smart Battery Charger	Standard
Automatic Voltage Regulator	Standard
Automatic Low Oil Level Shutdown	Standard
Overspeed Shutdown	Standard
Underspeed Shutdown	Standard
High Temperature Shutdown	Standard
Overcrank Protection	Standard
Safety Fused	Standard
Wiring Error Detection	Standard
Battery Problem Warning	Standard
Charger Problem Warning	Standard
RPM Sensor Loss Shutdown	Standard
Maintenance Indicators (Indicate Break-in and Regular Maintenance is due)	Standard

**Sound levels are taken from the front of the generator. Sound levels taken from other sides of the generator may be higher depending on installation parameters. Rating definitions - Standby: Applicable for supplying emergency power for the duration of the utility power outage. No overload capability is available for this rating. (All ratings in accordance with BS5514, ISO3046 and DIN6271). * Maximum wattage and current are subject to and limited by such factors as fuel Btu/megajoule content, ambient temperature, altitude, engine power and condition, etc. Maximum power decreases about 3.5 percent for each 1,000 feet (304.8 meters) above sea level; and also will decrease about 1 percent for each 6 °C (10 °F) above 16 °C (60 °F).

PowerPact™ System - 5.6

GENERAC®
available accessories

Model #	Product	Description
G006882-0	Cold Weather Kit	The cold weather kit is required for PowerPact units installed in regions where the temperature regularly falls below 32 °F (0 °C).
G006806-0	Scheduled Maintenance Kit	Generac's scheduled maintenance kits provide all the hardware necessary to perform complete routine maintenance on a Generac automatic standby generator.
G005703-0	Paint Kit	If the generator enclosure is scratched or damaged, it is important to touch-up the paint to protect from future corrosion. The paint kit includes the necessary paint to properly maintain or touch-up a generator enclosure.
G006664-0	Local Wireless Remote	Completely wireless and battery powered, Generac's wireless remote monitor provides you with instant status information without ever leaving the house.

dimensions & UPCs

Dimensions shown are approximate. Refer to installation manual for exact dimensions. DO NOT USE THESE DIMENSIONS FOR INSTALLATION PURPOSES.

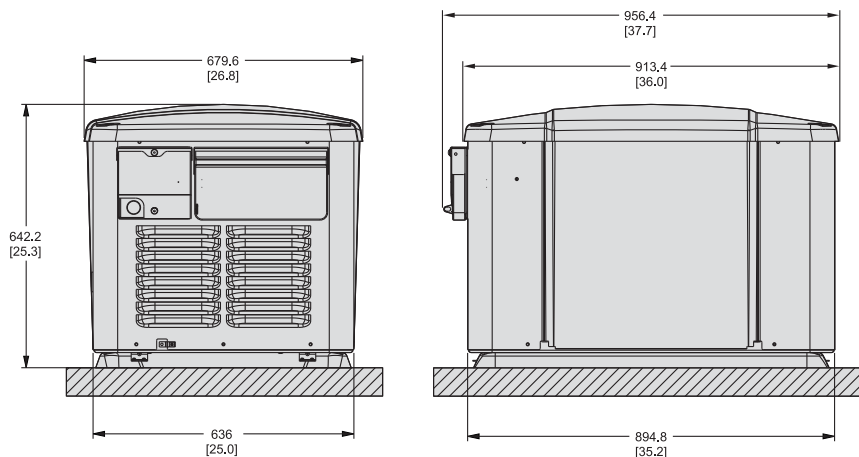

LEFT SIDE VIEW

FRONT SIDE VIEW

Model	UPC
G006520-1	696471065206

GENERAC®

Generac Power Systems, Inc. • S45 W29290 HWY. 59, Waukesha, WI 53189 • generac.com

©2016 Generac Power Systems, Inc. All rights reserved. All specifications are subject to change without notice. Part No. 0L3429-C 9/13/16